

HX

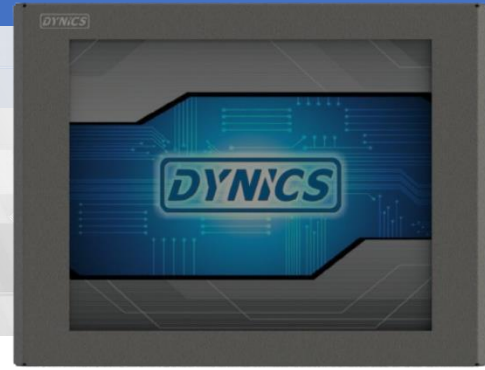

HX | Enclosed Unit with Integrated PC

DYNICS HX Monitor is an IP65 rated fully sealed enclosure, designed for industrial applications.

- NEMA 12/4/4X
- IP65/66
- 100~240VAC (3-Pin) / 24VDC (4-Pin)
- VESA / Wall Bracket Mount System with Up to 20° Tilt

DISPLAY SPECIFICATIONS

	15"	17"	19"
SIZE	XGA 1024 x 768	SXGA 1280 x 1024	SXGA 1280 x 1024
RESOLUTION	H: -80°/+80°, V: -80°/+80°	H: -85°/+85°, V: -80°/+80°	H: -85°/+85°, V: -80°/+80°
VIEW ANGLE	600:1	1000:1	1000:1
CONTRAST	350 nits	350 nits	350 nits
BRIGHTNESS	4:3	5:4	5:4
ASPECT RATIO	5-Wire Analog Resistive (Touch Screen) / Protective Polycarbonate Lens (Non-Touch)		
LENS	50,000 Hour Backlight Half-Life		
LCD LIFE	NEMA 12/4 Powder Coat Finish (Graphite Gray) / NEMA 4X Stainless Steel		
ENCLOSURE	0-20° Tilt Bracket included with 60,100,150,200, & 250 VESA mounts (can also be used for wall mounting)		

PC SPECIFICATIONS

	Intel® Apollo Lake	Intel® 8th Gen Whiskey Lake
COMPUTER I/O		
Ethernet Ports	2x	2x
USB 3.0 Ports	2x	2x
CPU	Intel® Apollo Lake N4200	Intel® Core™ i5 8265U / i7 8565U
CPU SPEED	2.5 GHz, 2MB Cache (4 Cores, 4 Threads)	i5 – up to 3.9GHz, 6MB Cache (4 Cores, 8 Threads) i7 – up to 4.6GHz, 8MB Cache (4 Cores, 8 Threads)
MEMORY STORAGE	Up to 32GB DDR4	
OPERATING SYSTEM	256GB – 2TB SATA SSD / 1TB HDD	
	- Windows® 10 Enterprise IoT LTSC 2019 (64-bit) (Code: E19)	
	- Windows® 10 Enterprise IoT LTSC 2021 (64-bit) (Code: E21)	
	- Windows® 10 Pro (64-bit) (Code: W10)	
	- Windows® 11 Pro (64-bit) (Code: W11)	
	- Linux® Ubuntu® (Contact DYNICS for more details) (Code: LUB)	
	- Optional Custom OS (Code: COS)	
POWER SUPPLY	100~240VAC (3-Pin) / 24VDC (4-Pin) Power Entry	
TEMPERATURE	Operating: 0°-50°C 32°-122°F	
	Non-Operating: -25°-60°C -13°-140°F	
RELATIVE HUMIDITY	Non-Condensing: 20% - 80%	
SHOCK RESISTANCE	Operating: 10G	
	Non-Operating: 15G	
VIBRATION	Operating: 1.0G from 57~2000Hz	
	Non-Operating: 2.5G from 57~2000Hz	
ALTITUDE	Maximum altitude of 2,000 meters	
INCLUDED COMPLIANCE	1x (3-Pin) Mini Power Cable (AC Only) / 1x (4-Pin) Quick Disconnect (DC Only)	
WARRANTY	European Union Directive 2011/65/EU (RoHS)	
	24-Month limited warranty. Extended warranty available, contact DYNICS for more details.	



HX

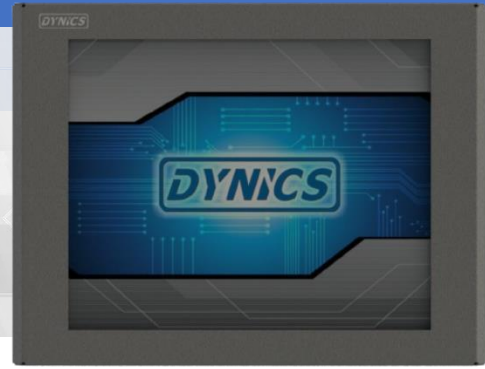

DIMENSIONS, WEIGHT AND POWER CONSUMPTION

	15"	17"	19"
HEIGHT	11.752" (298.5mm)	14.580" (370.3mm)	15.050" (382.3mm)
WIDTH	17.481" (444.0mm)	17.983" (456.8mm)	19.704" (500.5mm)
DEPTH	5.040" (128.0mm)	6.0" (152.4mm)	5.076" (128.9mm)
WEIGHT	16.72 lbs.*	24.40 lbs.*	17.14 lbs.*
POWER CONSUMPTION	40 Watts**	50 Watts**	55 Watts**

* Weights are approximate, contact DYNICS for details.

** Power consumption is based on maximum ratings, actual ratings vary significantly based on components used.

MECHANICAL DRAWINGS

FRONT VIEW

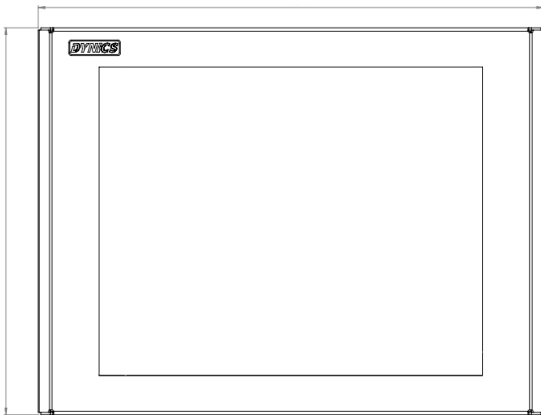

ISO VIEW

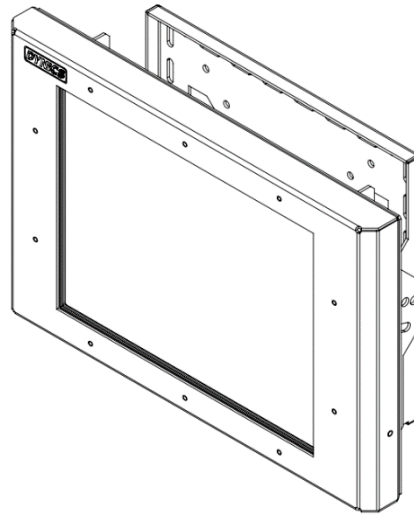

SIDE VIEWS

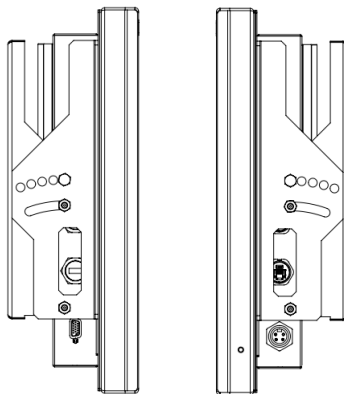

POWER ENTRY

(3-Pin) 100~240VAC



- 1 GROUND
- 2 LINE
- 3 NEUTRAL

(4-Pin) 24VDC

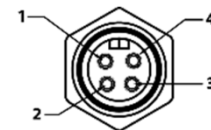

- 1 NO CONNECT
- 2 0 VDC
- 3 NO CONNECT
- 4 +24 VDC

All measurements are in inches and pounds, unless noted. Pictures and drawings are not to scale. Estimated weight may change depending on options. DYNICS reserves the right to change, modify, upgrade, or discontinue any part of this datasheet without any prior notice.